

## Low cost coil winder

The Renesas RSK2329 board is used to control a stepper motor based coil winder. The coil winder hardware is constructed out of  $\frac{3}{4}$  inch MDF board and commonly available 28TPI threaded rod. Using 7.2 degree per step unipolar stepper motors a theoretical stepping precision of 0.0007 inch/step is achieved, the system has surprisingly low backlash. This system is ideal for hobbyist or small quantity production of flyback transformers, or special rf chokes etc. Coils with lengths upto 12 inches can be accommodated, this enables very easy winding of tesla coil type transformers also. Also the use of commonly available hardware ensure that any one can make this without access to metal machining machines. User interface to the winder is provided via the evaluation board LCD and a PC AT keyboard.

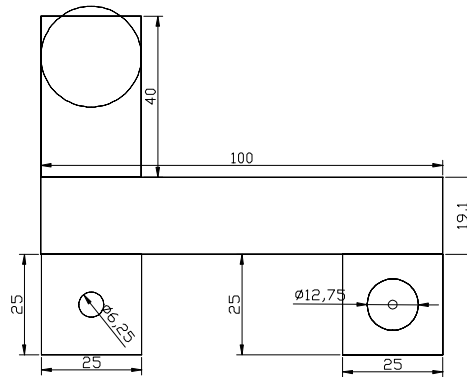

## Carriage Winder details

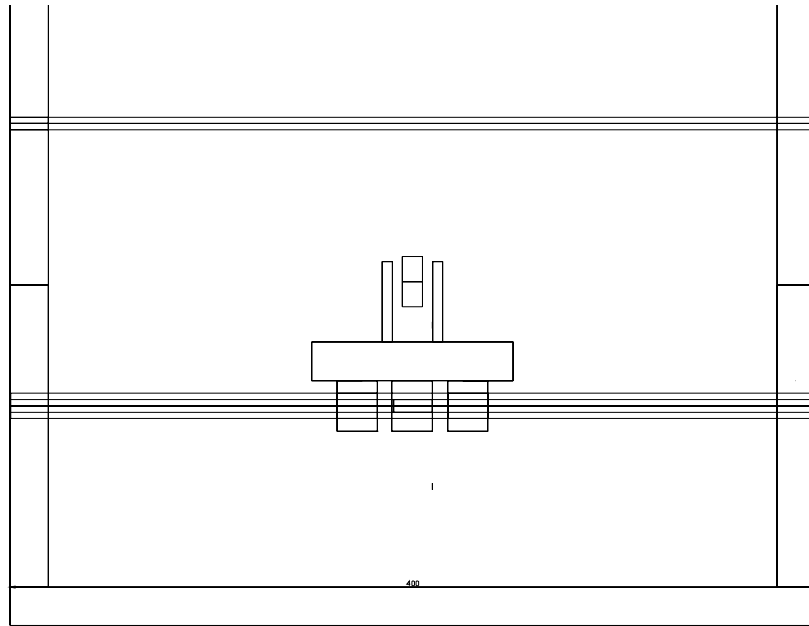

**Coil winder front view**



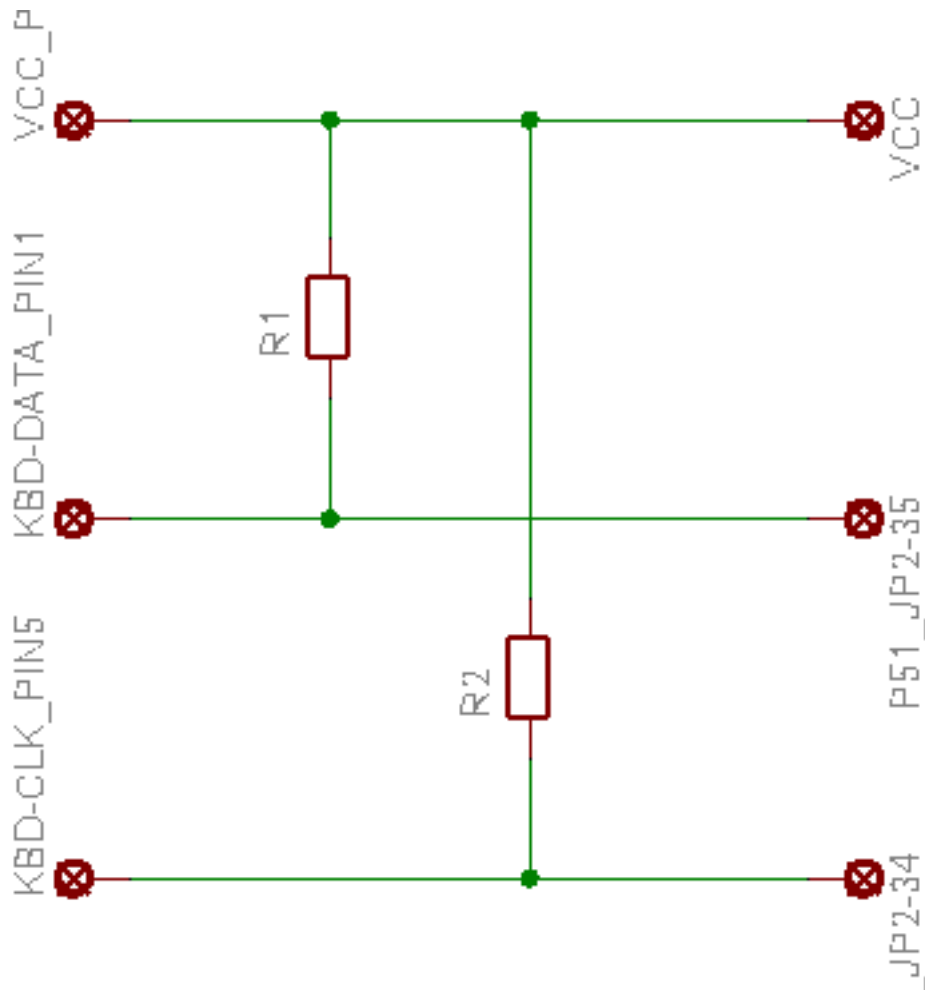

## Software:

Simple round robin scheduler schedules the following three tasks in sequence. The software cycle time is 4ms so each of this task is scheduled within that window.

processCommands(); - Processes keyboard commands  
 run\_motors(); - drives the stepper motors for carriage and winder  
 displayWindData(); - Displays winder progress

Using the coil winder:

The winder starts out by asking user to Jog the carriage to the start of the coil bobbin, you could use absolute measurements, but I decided to use a manual jog as it made things easier and I did not have to worry about limit switches etc.

Once the start and end positions of the bobbin are registered, the user is prompted for the wire gage. The software calculates the slide movement required per turn based on the gage. Next the user enter the number of turns that will be wound on the bobbin. Once all the parameters are entered hitting space start the winding process.

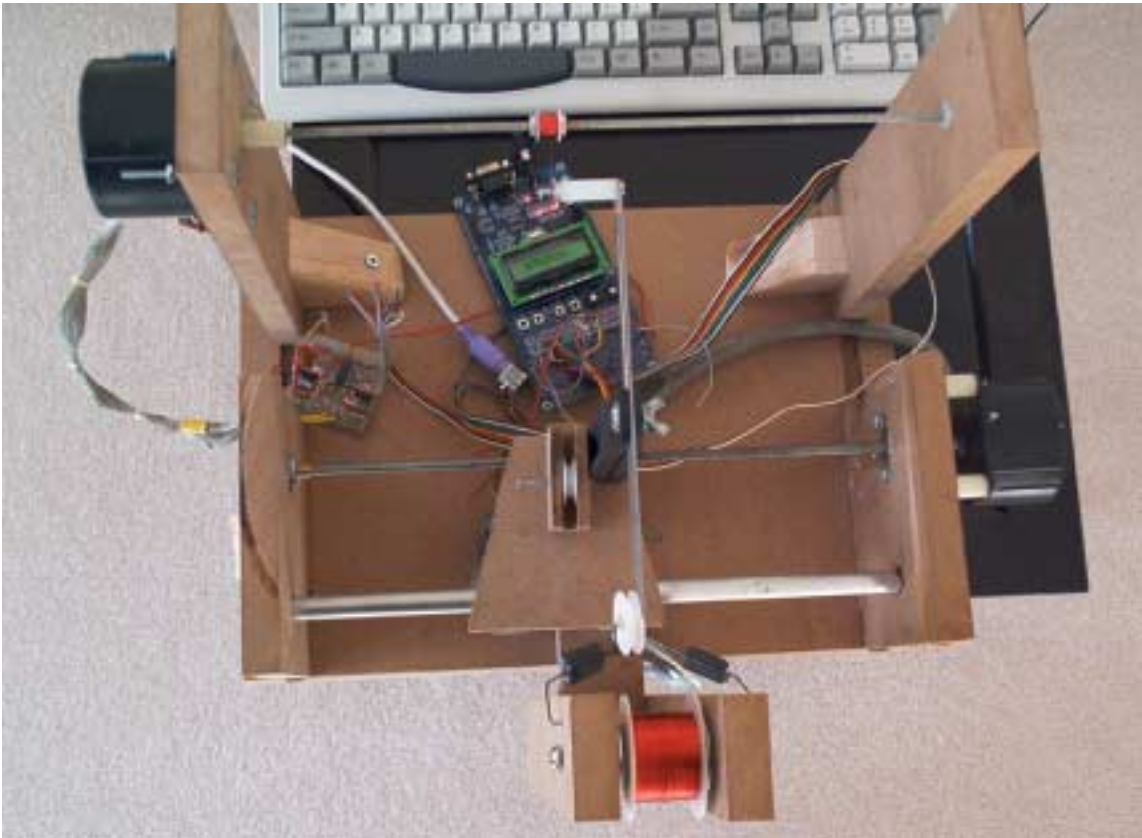

**Figure A**