

CONTEST ENTRY C2937

Pocket Heart Monitor

ABSTRACT

This project describes a simple low-cost electrocardiograph (ECG) heart monitor, which uses the PSOC as the main signal processor and display controller. An instrumentation amplifier is used to process low-amplitude differential signals picked up by two ECG probes, placed on either side of the heart. The output from the amplifier is passed into to the PSOC, where it is buffered, filtered and sampled. The sampled-time signal is then displayed as a chart on a small graphical LCD.

DISCLAIMER

This design has not been tested against relevant medical safety standards and is therefore only intended only as a demonstration. The author does not take any responsibility for damage or injury arising from use of the design.

INTRODUCTION

The ECG measures and displays movements in the heart muscles, which typically generate changes in voltage in the range of $\pm 5\text{mV}$, in the frequency range of 0.1 to 100 Hz. To complicate the sensing, the body also tends to pickup nearby 50-60 Hz mains voltage signals, which appear as relatively large, superimposed common-mode signals. For this reason, a special-purpose instrumentation amplifier with a very high common-mode rejection ratio (CMRR) was chosen to pre-process the ECG pickups before passing the signal onto the PSOC for processing.

The PSOC processing initially buffers the signal using a unity-gain op-amp. The signal is then sampled digitally using a 12-bit ADC, converted to AC by subtracting a running average DC offset, and then scaled and plotted on a 122x32 graphic LCD in a chart recorder-style display.

To further reduce the amplitude of the common-mode signal pickup, an anti-phase common-mode signal is generated by the PSOC. This is optionally fed back into the body typically via another ECG probe placed on the right leg (hence its name 'right leg drive').

The circuit is powered by the output from two 1.5V batteries, which is converted up to 5Vdc using a small boost converter and the PSOC's onboard boost regulator. This allows the circuit to be incorporated into a portable application, and also eliminates the isolation safety issues with using mains-derived power.

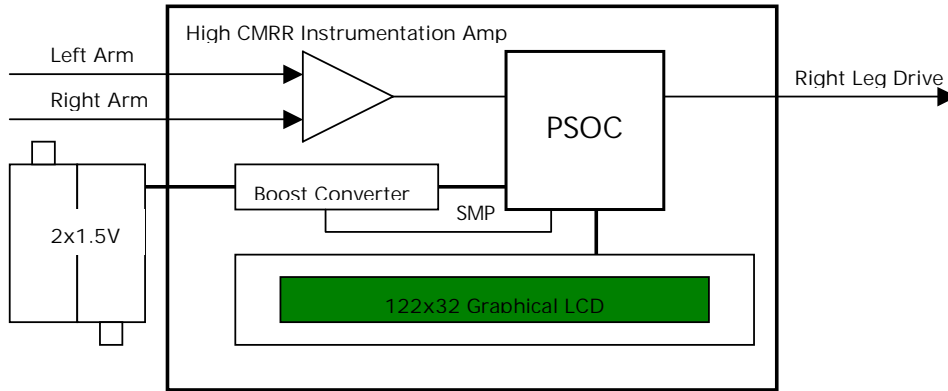

System Block Diagram

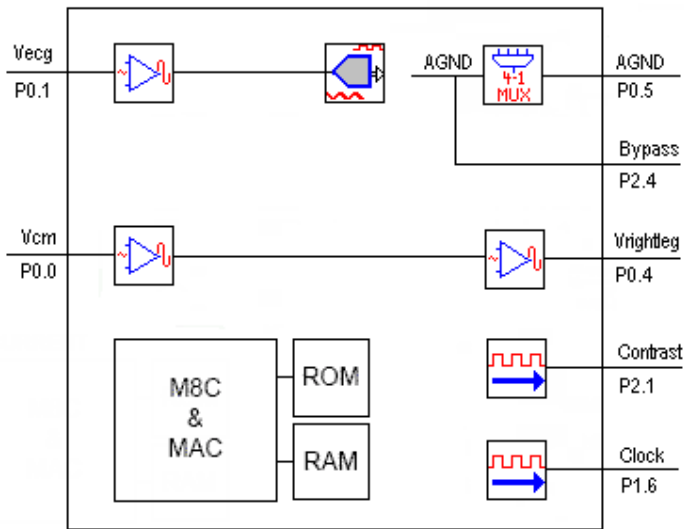

PSOC Internal Block Diagram

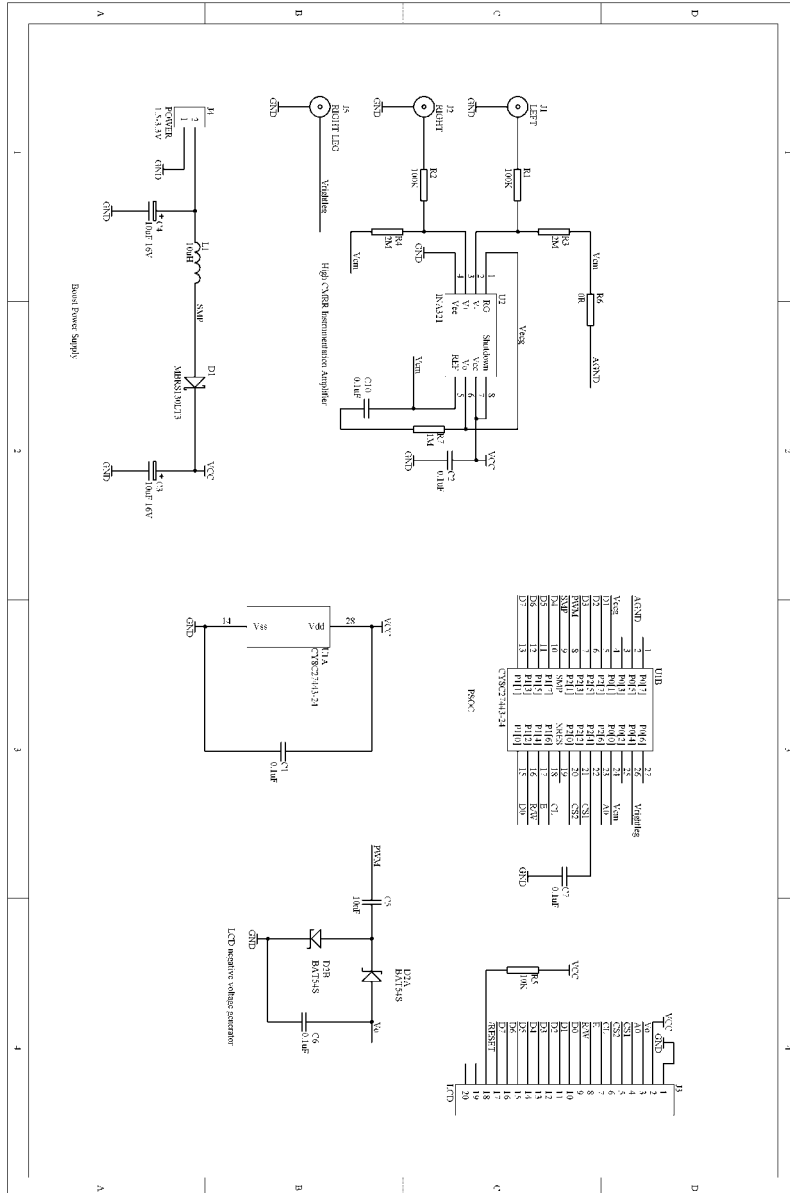

Top-level schematic



Prototype PCB (ECG lead connectors shown on right)

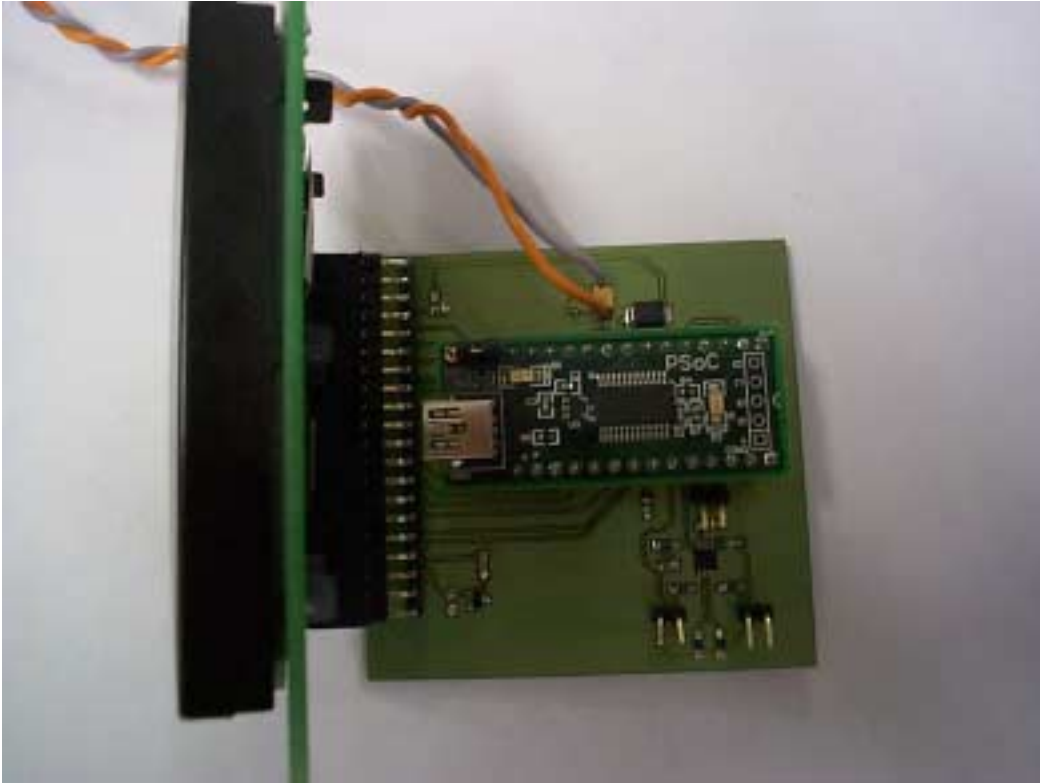

Prototype PCB top view