

# Remote Observation Station

Entry #F2040

## *Abstract*

Ever wonder what the birds, deer, or bear were doing in your back “40” when you weren’t around? Just set up the Remote Observation Station, and you can watch the wildlife on your TV in the comfort of your living room! The station includes a camera and transmitter that sends a picture to your TV, which can be up to a mile or two away. The station gets its power from a PV solar panel and a rechargeable battery, which rely upon the system’s control board for direction. The control board also produces battery state information, which it overlays on the picture sent to your TV. So, while you’re watching Bambi, you can also monitor the status of your battery.

The unit integrates six electronic devices including: a CCD video camera, a PV solar panel, a rechargeable battery, a temperature sensor, an RF video transmitter, and the system control board (PVCC). The control board is based on Motorola’s MC68HC908QY4 MCU and sits at the center of the system providing a PV charge controller, two high efficiency voltage regulators, a video sync separator, and an RS232 serial interface for system configuration.

The PVCC control board provides a simple On/Off battery charger using the PV solar panel as a power source. The primary job of the charge controller is to prevent the battery from being overcharged. The control board also adds battery state information in the form of a text overlay (on-screen display, or OSD) to the video signal generated by the CCD camera before it reaches the video transmitter. Additionally, a PC can be connected to the control board via the DB9 connector.

The system has three operating modes: the Configuration Mode, which allows the user to set up its behavior via their PC; the Charge Control Mode with OSD, where the battery’s voltage and temperature are overlaid on to the video signal for feedback to the user; and the Charge Control Mode without OSD, for when the user doesn’t need the diagnostic display. The PVCC Configuration Utility communicates with the PVCC board while in the Configuration Mode. With this utility, the user can set a variety of options, including the full charge set point (the Off set point) and the PV reconnect set point (the On set point). The user can also choose to enable the transmission of an Amateur Radio call-sign if a HAM frequency is being used.



**Photograph 1: The on-screen display**

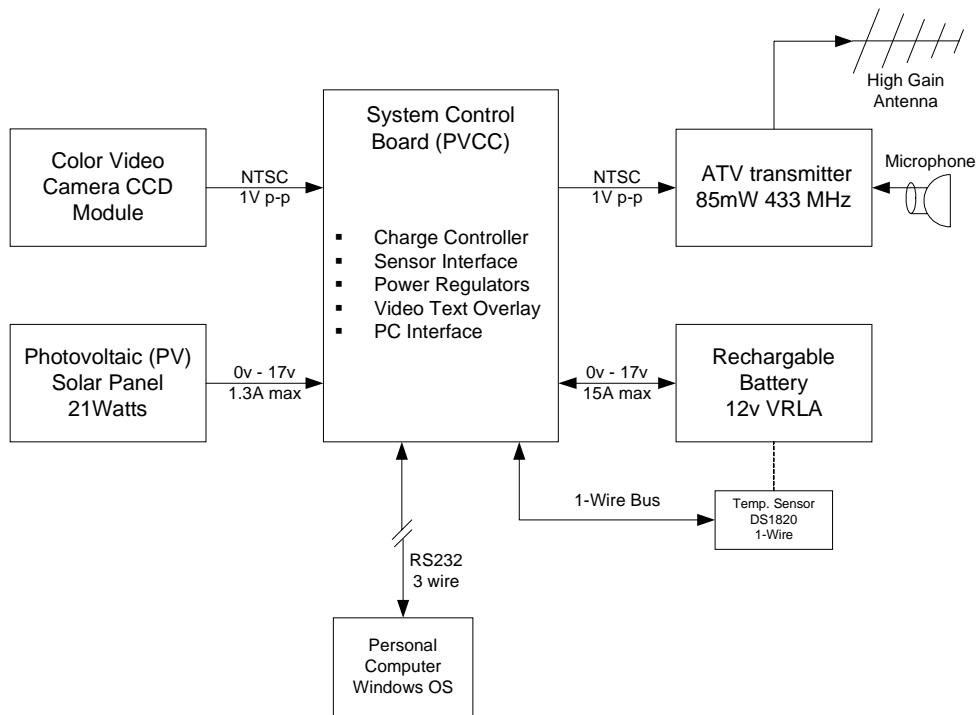

**Figure 1: Remote Observation Station Block Diagram**

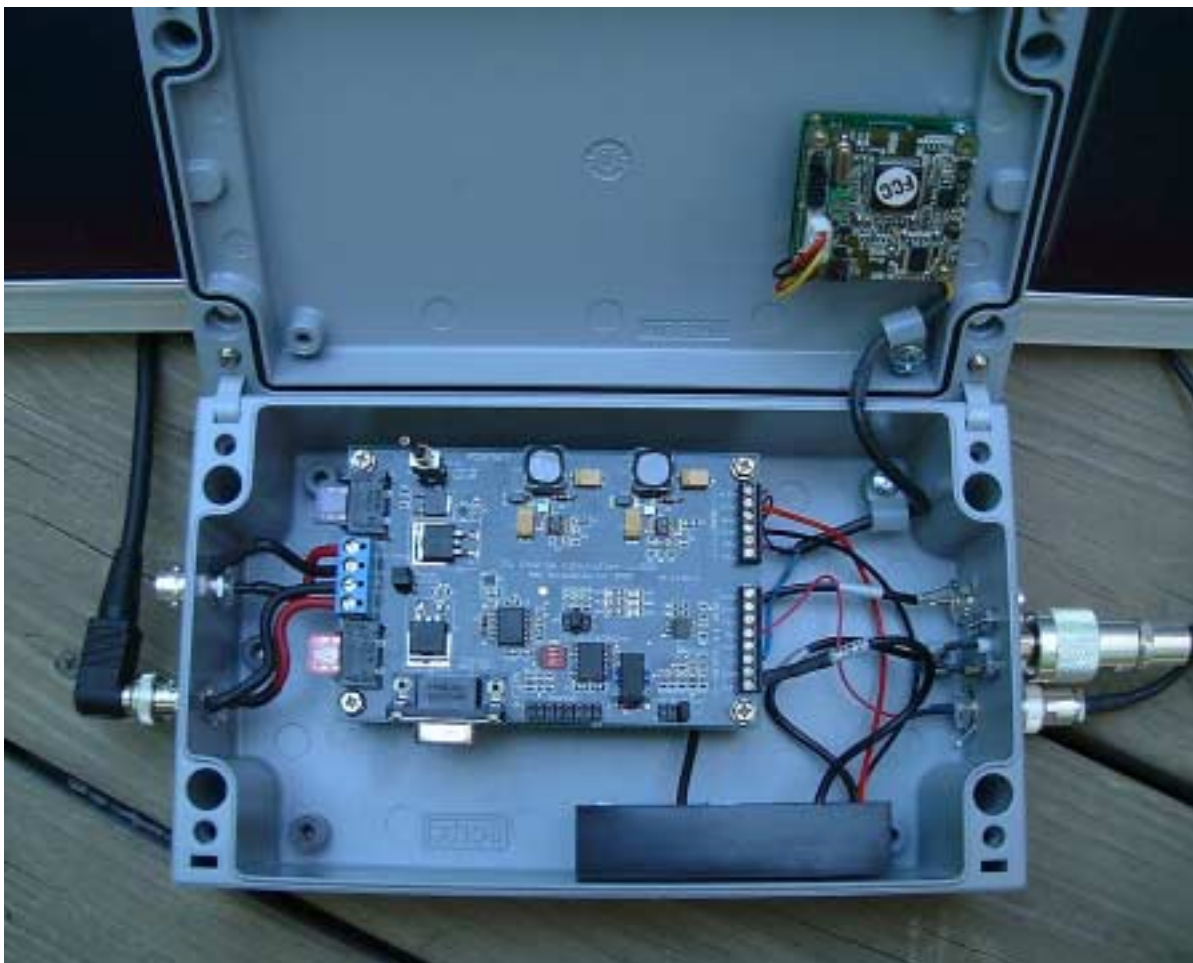

**Photograph 2: The Remote Observation Station** (Not Pictured: Battery and Temp. Sensor)

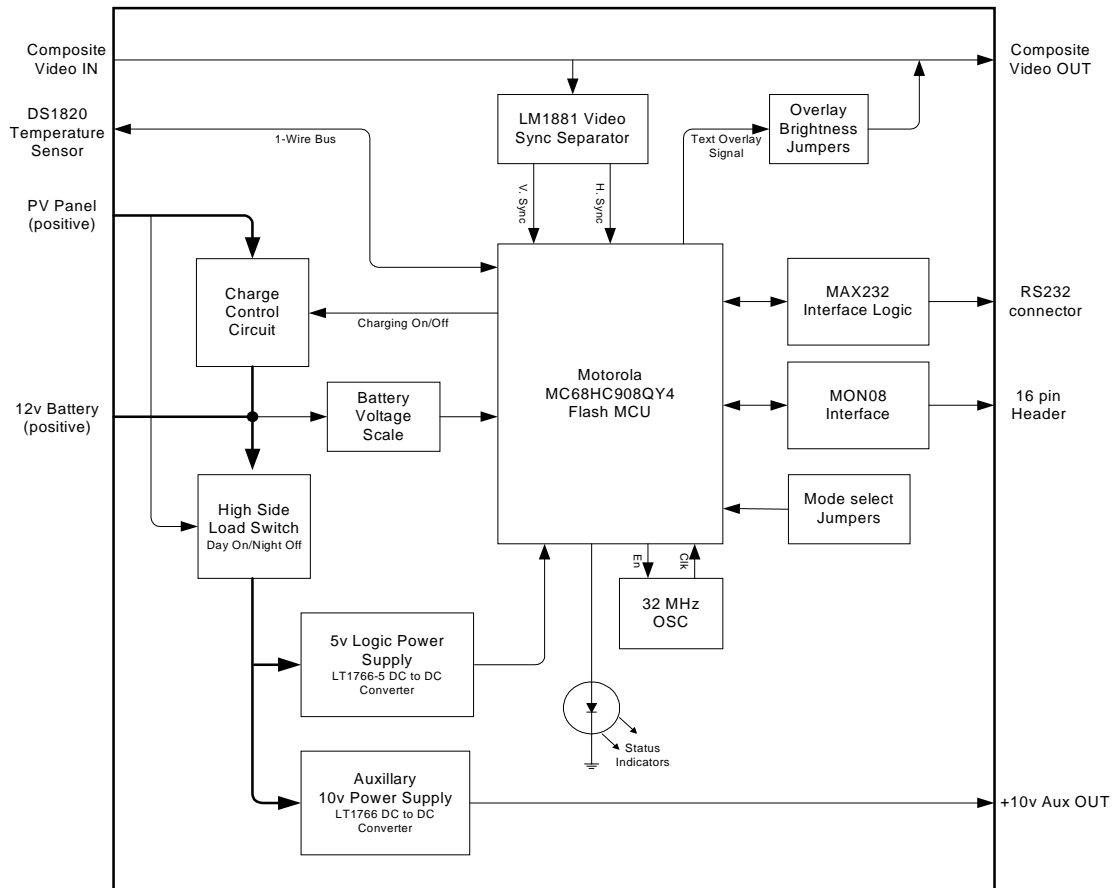

**Figure 2: Block Diagram PVCC control Board**



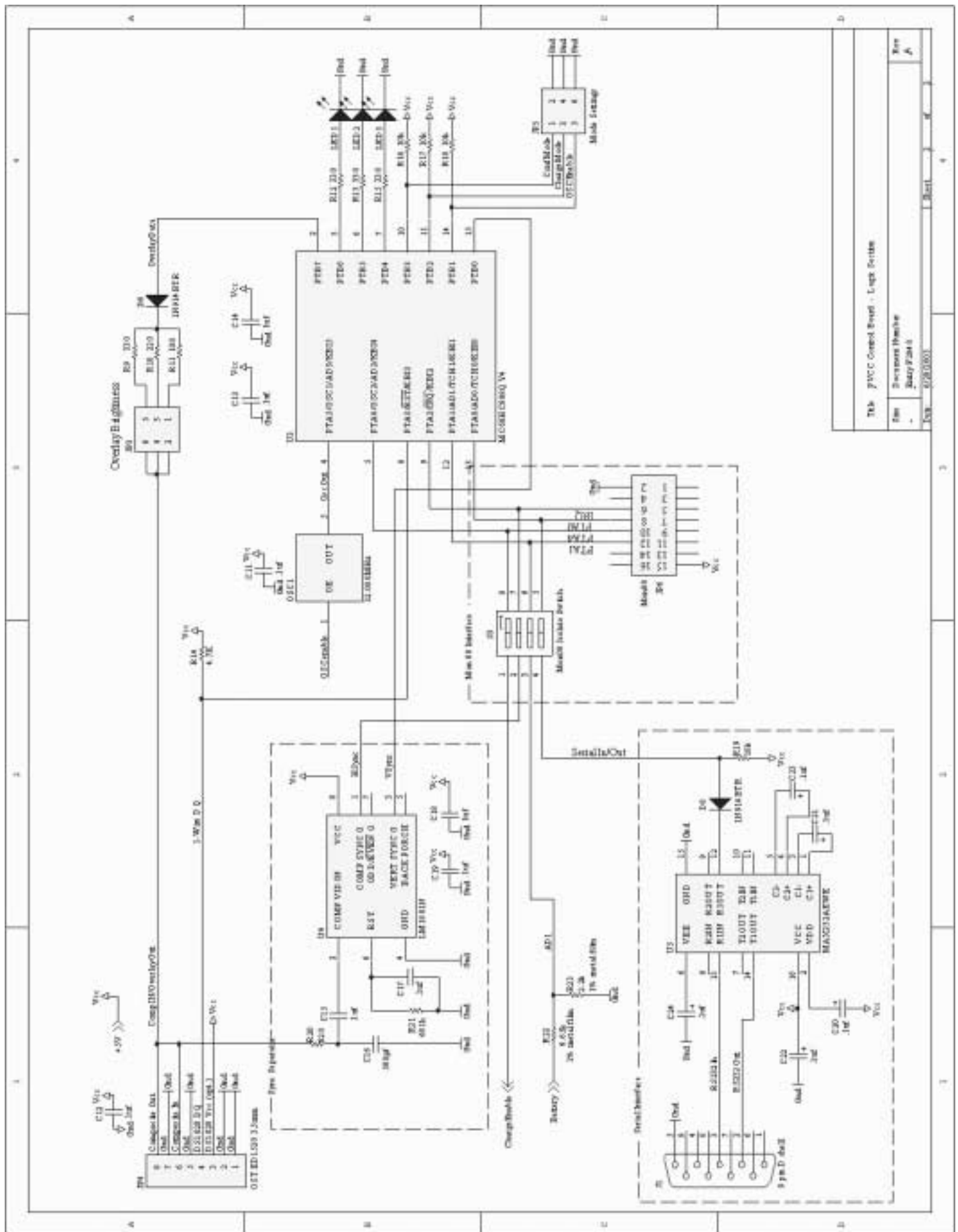

Figure 3b: PVCC schematic – logic section

## Source Code Sample

The following is a sample of source code. This code appears near the beginning of the file. It is responsible for checking the configuration data stored in FLASH for validity (good CRC). If found to be invalid, default values are copied over the top of the old configuration data.

```
; CRC check product configuration data stored in FLASH for validity. If not valid, write new Config data from default data.
; This code should execute from the internal OSC, and the MCU CONFIG registers should be programmed
; after this code.
;
    ldhx #CONFIG_DATA
    aix  #2                ; Do not include the stored CRC value in the current CRC calculation
    lda  #LOW(CONFIG_DATA_SIZE)
    deca
    deca                    ; Subtract 2, CRC value in setup is not included in local CRC calculation

    jsr  CRC16              ; Compute CRC16, returns CRC in H:X
    cpx  CONFIG_CRC+1       ; Check high and low byte for match with stored value
    bne  LoadDefaultConfig
    pshh
    pulx
    cpx  CONFIG_CRC
    beq  CheckSystemMode

; Config data didn't pass CRC, so write new default setup data vaules to FLASH memory
LoadDefaultConfig:
    sta  COPCTL             ; service COP control register to prevent COP reset
    clrh
    ldx  #LOW(CONFIG_DATA_SIZE)
CopyLoop:
    lda  DefaultConfigData-1,x    ; Move Default Config Data to RAM for programming into FLASH
    sta  DATA-1,x
    dbnzx CopyLoop

; Calculate the new CRC16 for the data just copied to RAM location DATA
    ldhx #DATA+2
    lda  #LOW(CONFIG_DATA_SIZE)
    deca
    deca                    ; Subtract 2, CRC value in setup is not included in local CRC calculation
    jsr  CRC16              ; Compute CRC16, returns CRC in H:X
    sthx DATA

; Erase 64 Bytes starting at lable CONFIG_DATA.
    mov  #13, CPUSPD
    bclr 6, CtrlByt        ;Flag to erase a single page
    ldhx #CONFIG_DATA
    jsr  ERARNGE

; Program Configuration data into flash
    ldhx #(CONFIG_DATA+CONFIG_DATA_SIZE-1)
    sthx LADDR
                                mov  #13, CPUSPD                ; 3.2MHz/0.25MHz = 13
                                clr  CtrlByt                    ; Page (not mass) erase
                                ldhx #CONFIG_DATA

    jsr  PRGRNGE
```