

# MOTOROLA Flash Innovation 2003 Design Contest

## Project No. F2033

### i-Button based Personal Identification System (iBPIS)

#### Abstract

I-cards, punched cards, magnetic cards and many similar systems are in practice in almost all organization to identify their employees, record their attendance and entry authorization in restricted zones. i-Button based Personal Identification System (iBPIS) is a novice idea to store all person related information on MAXIM's memory i-Button (DS1973) and enquire it through a PC or Hand held device whenever required through an IR link. It consist of 3 major modules - a) i-Button User (iBU) module, i-Button Enquiry (iBE) module and i-Button Programming (iBP) module.

Motorola's little microcontroller MC68HC908QT4 sits in i-Button user module to communicate memory i-Button using 1-wire bus protocol soft coded in it and implement serial communication interface to transfer data at 9600 baud rate to and from MCP2120 (Microchip's IrDA encoder/decoder). MCP2120 will further communicate with Enquiry module using IrDA compliant IR transceivers TFDU4100 (Vishay Electronics). Data exchange between i-Button User module and Enquiry module takes place wirelessly using IR link. In this way information/data stored about any person in i-Button can be retrieved without making any physical contact. All components of user module can be fabricated in a small unit so that a user can easily wear it on wrist or at any convenient place from where IR signals can be received / transmitted.

PC based i-Button programmer is made using Maxim's DS2480B and MAX232 RS-232 level shifter. To store/update data in iButton, GUI Software "iBProg" written in VisualC++ using TMEX library is developed which implement data exchange between PC and iButton. i-Button Enquiry module is implemented through PC (rather than handheld unit) using software "iBReader" written in Visual C++ using IO.dll library which send command to user module through iBE hardware and then receive data to display in Read window. The 1-wire protocol and Serial Communication interface for iBU module is written in Assembly language using Code Warrior special edition for Motorola's HC08.

The use of iButton based identification system can be further extended to store health records or patient's data for data retrieval in emergency or for doctor's convenience.

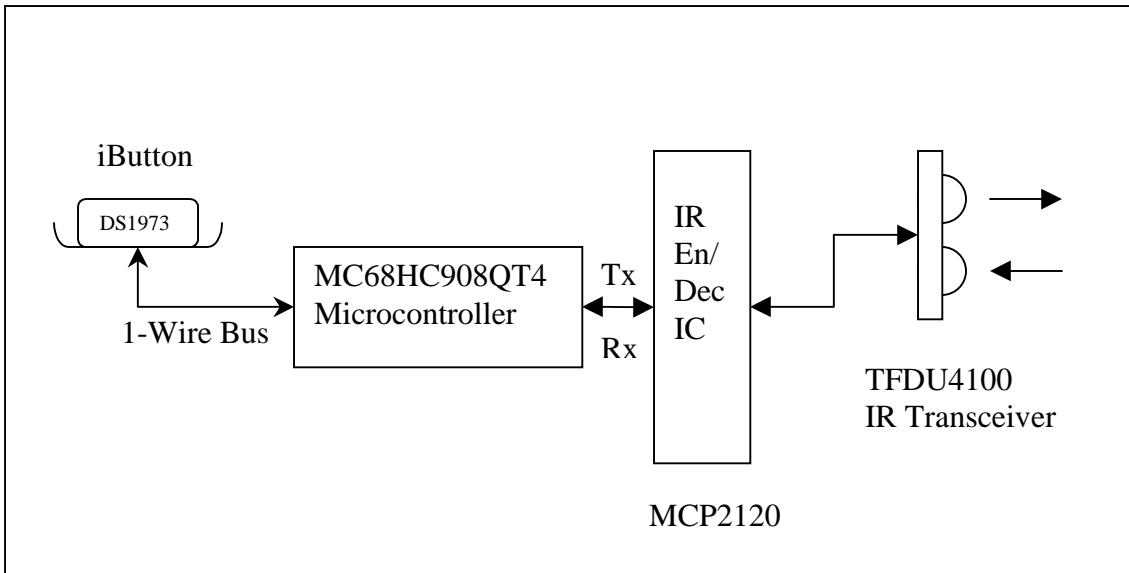
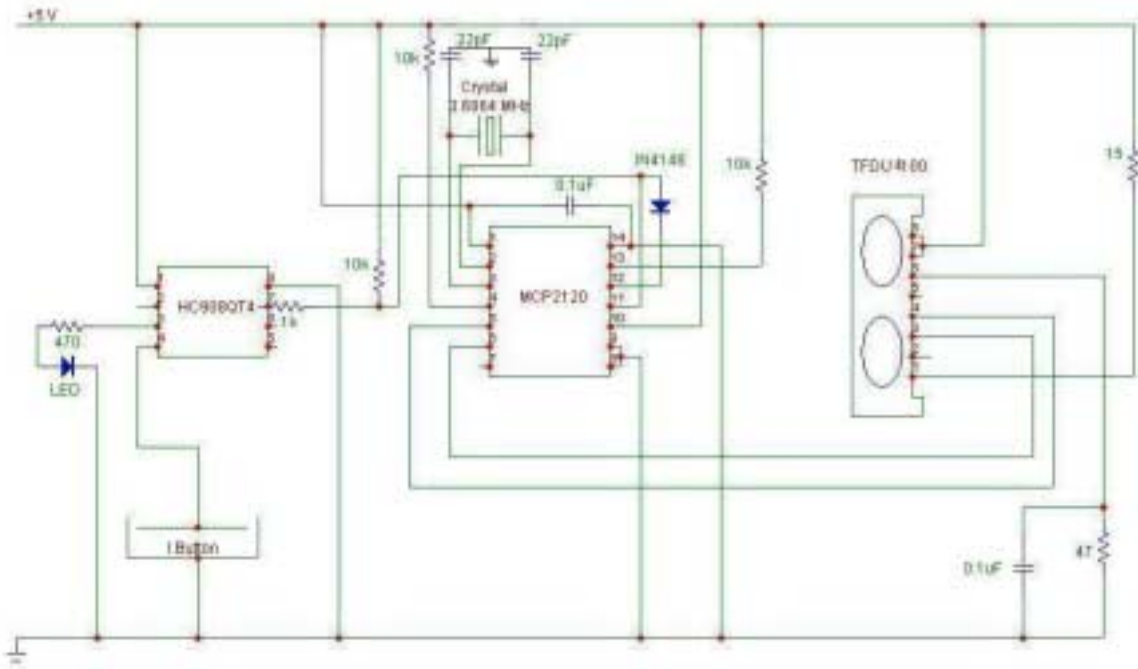

Fig. 1: Block Diagram of iButton User Module



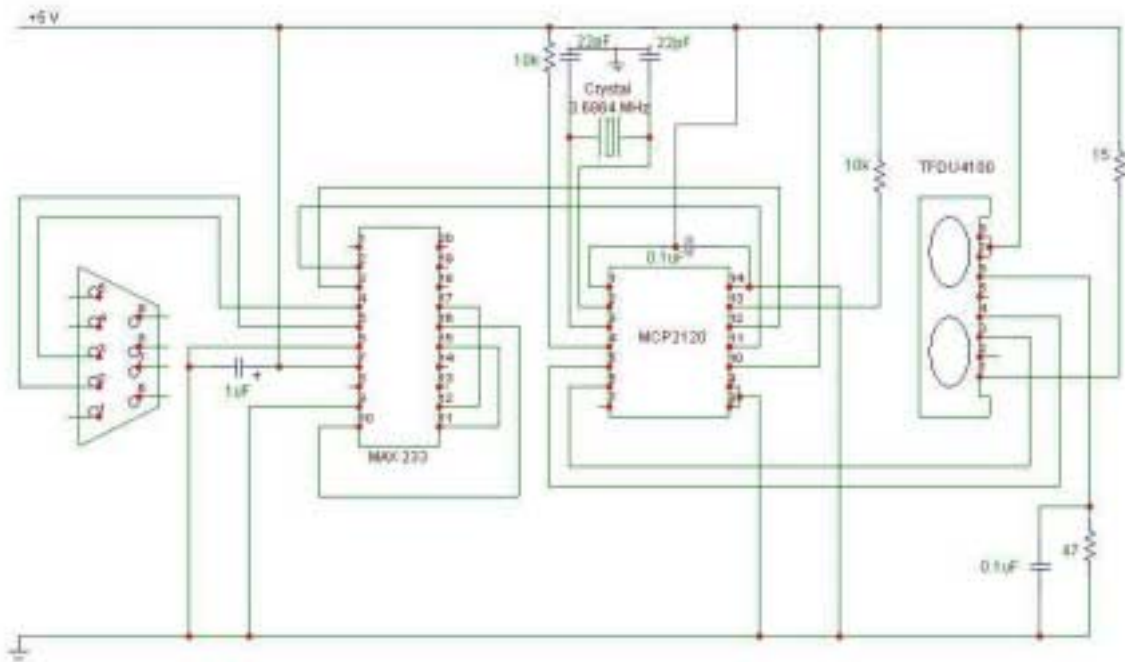
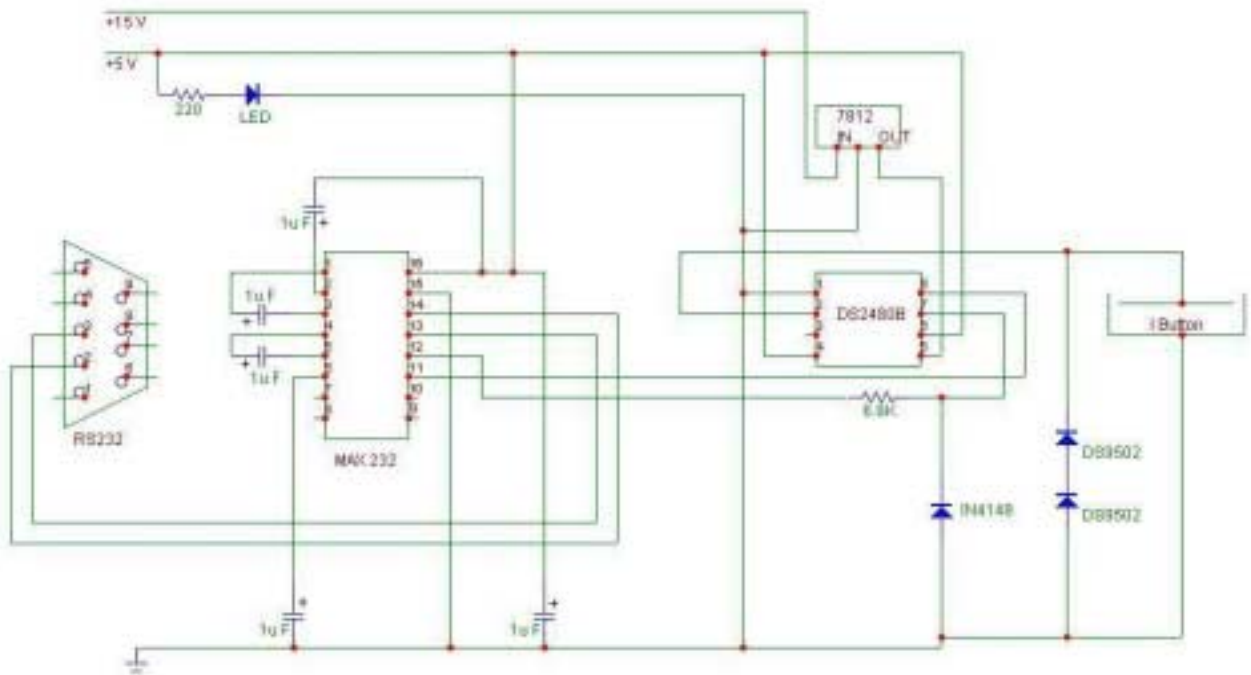
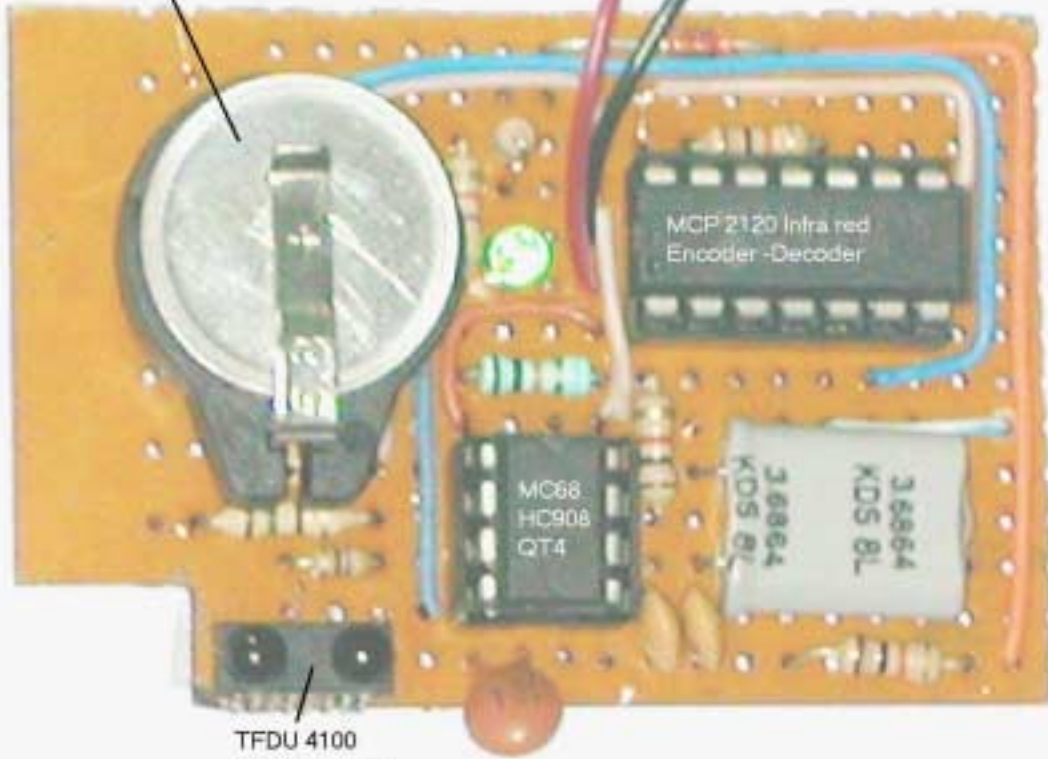

Fig. 8: Circuit diagram of iButton Enquiry Module (iBReader\_ckt.jpg)

The circuit diagram of iButton programming hardware is shown in Fig. 16 below:



DS1973 Memory i-Button



TFDU 4100  
IR Transceiver